

### APPLICATIONS:

Perfect for patio, front porch, yard, garden, driveway, pathway, attic, deck, etc.

### FEATURES:

Easy to install, waterproof and dust proof  
 High quality polysilicon solar panel  
 Main light is illuminated down, and soft side light around  
 Continuous dusk to dawn when full recharged  
 Built-in smart battery management chip

### SPECIFICATIONS:

SKU	9353	Dimensions	130x130x395 mm
Solar Panel	Polysilicon	Material	PC
Charging Time	5-6 Hours	Battery	3.7V/1200mAh Lithium Battery
LED Type	SMD 3528	Working Time	Max. 15+ Hours
Surface Color	Matt Black	LED Q'ty	8 Pcs
IP Class	IP65	Color Temp.	3000 K
Working Temp	-10~45 °C	Weight	0.20 Kgs

### IMPORTANT:

- This is a solar powered light and must be installed where can get enough sunlight.
- Install in direct sunlight for best results.
- Recommended installation is facing South, with no shade or obstruction above the light.
- Keep it away from other light sources, such as street lights, corridor lights, etc. Because when the solar panel detects sufficient light from these light sources, it will mistakenly think it is daytime and the lamp will not work.
- Fallen leaves, built-up dirt or dust will affect the performance of solar charging. Please wipe off the debris gently on the solar panel with a damp cloth monthly.

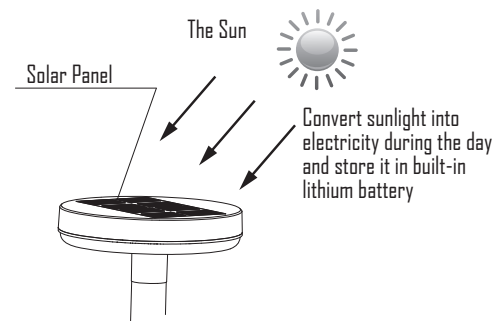

● BEFORE USING IT FOR THE FIRST TIME, PLEASE BE SURE TO CHARGE IT IN THE SUN FOR AT LEAST 8 HOURS!

 When you get the light, the battery may be low due to natural discharge.

## LED Solar Garden Lights User Manual



# 1

## PACKAGE CONTENTS:

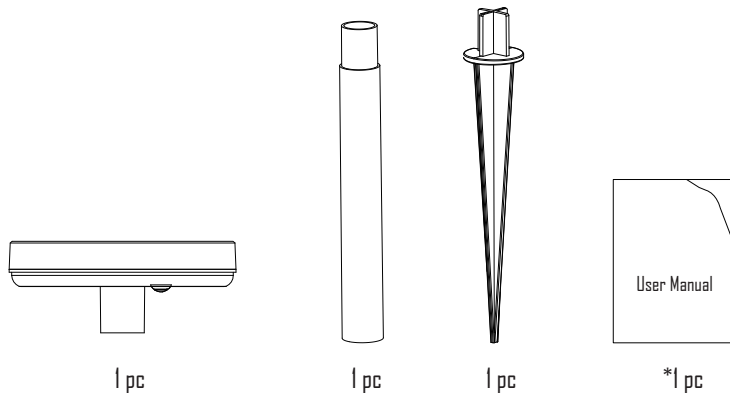

The above number of parts is the amount of one lamp. If there is a PACK set, the number of parts will be a multiple of the above.

\*There is only 1 pc user manual in each individual package.

## INSTALLATION :

Choose a place that can get enough sunshine to install the light, the more it gets sunshine, the longer it can illuminate.

### Ground Inserted

- ① Connect the ground spike with the light.
- ② Insert the whole spike into the ground vertically.

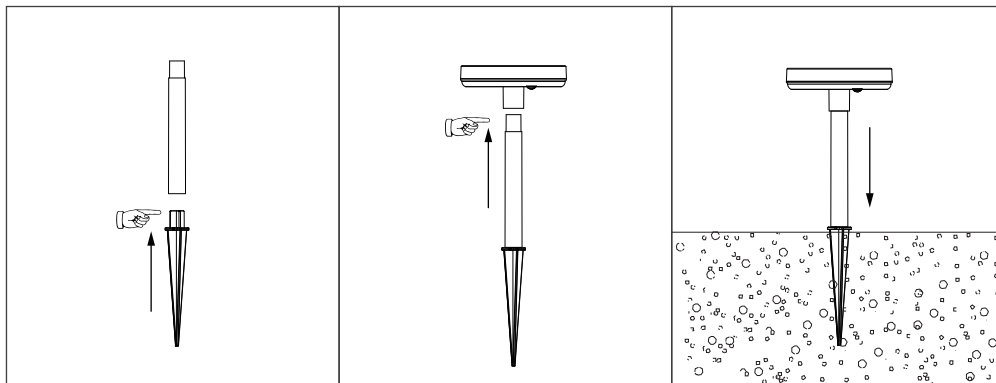

# 2

## OPERATION GUIDE:

The solar Landscape light can automatically detect surrounding brightness, it will not light up in the day, and it will automatically light up in darkness or at night. ☾

The default mode of the product is **OFF**. Press the back button to adjust modes when using the product.

It has 2 modes. You can adjust to a desired mode by pressing the back button.

**1. LOW Light Mode:**  
Press the button for once.

**2. HIGH Light Mode:**  
On the basis of LOW Light Mode, press the button again.

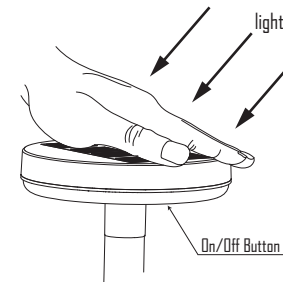
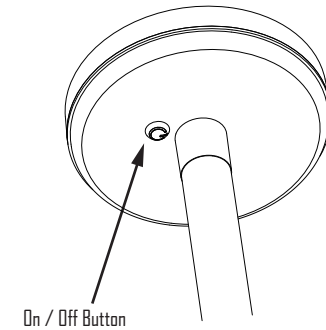

### ☀ Daytime

During the daytime or in a bright environment, if you want to test if it works, just cover the solar panel with your hand (or your body, a book, etc.) and turn on the switch.

### 🔋 Low Battery

When the battery is low, the brightness will automatically decrease, even in HIGH Light Mode. It is normal and not damaged.

### 🔋 Battery Protection

When the battery is extremely low, it will enter the battery protection mode and the solar Landscape light will stop working.

### ⚡ About Charging

No matter which mode the power button is in, if the sun is shining enough, the solar panel will always charging until the battery is full.